

The Kinnex 2.0 uses cutting-edge microprocessor technology to provide superior ground compliance for low to moderate impact ambulators (K3) for everyday activities. The new hydraulic system has been optimised with improved seal technology and a robust cylinder design. The Kinnex 2.0 delivers reliable energy storage and return throughout the day, thanks to its increased durability.

Waterproof\*

\*Waterproof note: The Kinnex should not be immersed in salt water or chlorinated water - if exposed to salt water or chlorinated water, immediately rinse with fresh water and dry.



Features and Benefits

- Sensor-controlled ankle movement reads and processes data at a rate of 200 times per second, and Rapid Response™ valve technology responds at a rate of 5 milliseconds
- The carbon fibre split heel and keel design provides optimal support and range of motion to reduce internal socket pressure, helping to accommodate obstacles and uneven terrain
- Clinicians can use the GaitLab app to lock the ankle in a neutral position for alignment and calibration, customise the setup of the device, and monitor outcomes using the GaitLab app
- New hydraulic oil reservoir and seal technology for increased oil capacity and longevity
- IP67 rated - up to 30 minutes in 1 metre of fresh water
- Dynamic lock provides a firm foundation, and can be engaged/disengaged using the app or via the button panel on the front
- Apparel Assist Mode locks the foot at an angle, making it easier for the user to change clothes or footwear
- When the charge is below 20%, users will be alerted by a soft vibration and low profile light on the button panel
- Up to 2" of heel height adjustment allows users to program up to 100 shoe styles
- 20° plantar flexion and 10° dorsiflexion range of motion means the foot is ideally positioned with the ground
- User App allows the user to make limited fine resistance adjustments

Cosmetics



Sandal toe: sizes 24-28 only

Ordering Information

Trial Period - Please speak to Customer Services or a Steeper Product Manager to organise a trial.

**Note:** Once the definitive foot has been purchased there is no trial period.

Impact Level Descriptions

**Low:** Daily activities include mostly level ground walking, moving around in the home and the community.

**Moderate:** Daily activities include up to unlimited walking, climbing stairs and occasional moderate lifting (this does not include running).

Ordering Example - NF14526SL

| Part Number | Category | Size (22-31) | Toe Configuration | Left/Right |
|-------------|----------|--------------|-------------------|------------|
| NF14        | 5        | 26           | S                 | L          |

Includes foot shell and Spectra® Sock

Category Selection

| Weight (kg) | Impact Level |     |
|-------------|--------------|-----|
|             | Low          | Mod |
| 44-52       | 1            | 1   |
| 53-59       | 1            | 2   |
| 60-68       | 2            | 3   |
| 69-77       | 3            | 4   |
| 78-88       | 4            | 5   |
| 89-100      | 5            | 6   |
| 101-116     | 6            | 7   |
| 117-125     | 7            | -   |

Toe Configuration

| Code        | Description  |
|-------------|--------------|
| Leave Blank | Regular      |
| S           | Sandal Toe** |

\*\*Sandal toe only available in sizes 24-28cm

Product Specification

| Weight Limit | Impact Level | Weight of Unit     | Sizes (cm) | Build Height (cm) | Battery Life | Warranty                           |
|--------------|--------------|--------------------|------------|-------------------|--------------|------------------------------------|
| 125kg        |              | 1432g<br>Size 25cm | 24-30      | 18.4 (size 25)    | 24 hours     | 3/5 years<br>Foot shell - 6 months |

Spare Parts Ordering Information

| Part Number         | Foot Shell Type        |
|---------------------|------------------------|
| NFTC-3K-1 ▲ ● 4-R ■ | Regular without CAP    |
| NFTC-2K-1 ▲ ● 4-S ■ | Sandal Toe without CAP |

Foot Shell Ordering Guide

- ▲ = Size in cm (24-30 = Regular, 24-28 = Sandal Toe)
- = Skin Tone (L = Light, M = Medium, D = Dark)
- = Side (R = Right, L = Left)

| Spectra® Sock    | Size (cm) | Sock Size |
|------------------|-----------|-----------|
| NSO-F14-00024-00 | 24        | 24cm      |
| NSO-F14-00025-00 | 25        | 25cm      |
| NSO-F14-00026-00 | 26        | 26cm      |
| NSO-F14-00027-00 | 27        | 27cm      |
| NSO-F14-00028-00 | 28        | 28cm      |
| NSO-F14-00029-00 | 29        | 29cm      |
| NSO-F14-00030-00 | 30        | 30cm      |

| Bumper Kit       | Size    |
|------------------|---------|
| NKIT-00-11403-00 | 24-25cm |
| NKIT-00-11404-00 | 26-28cm |
| NKIT-00-11405-00 | 29-30cm |

Additional Warranty Options

To order a Kinnex 2.0 foot with a five year warranty add the suffix '-5Y' to the end of the part number.

5 year warranty ordering example:

Kinnex 2.0 Foot & 5 Year Warranty, Cat. 5 Size 26 Regular Toe Left **NF14526L-5Y**

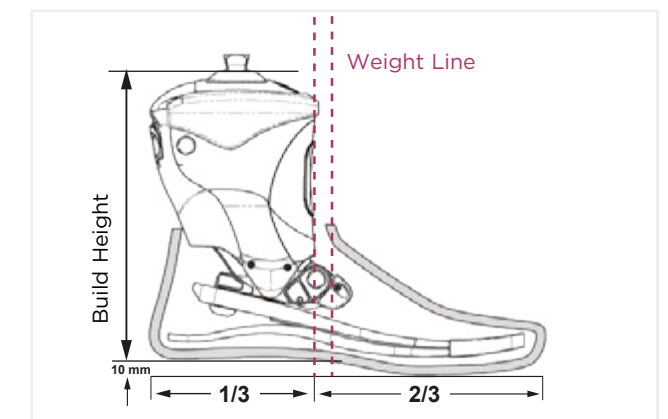

Technical Information

| Build Height and Weight |                   |                 |
|-------------------------|-------------------|-----------------|
| Size (cm)               | Build Height (cm) | Foot inc. Shell |
| 24-25                   | 18.4              | 1432g           |
| 26-28                   | 18.6              | 1494g           |
| 29-30                   | 18.6              | 1553g           |