

Streifeneder Locking Systems

The large choice of locking systems enables the technician to create a socket connection adapted to the patients' requirements. Every Streifeneder lock system unlocks under tensile load, which enables the patient to easily unlock the prosthesis even under tension, e.g. in a sitting position. A lockable mechanism is offered as an accessory for the clutch locks, which makes it easier for geriatric patients, in particular, to take off the prosthesis. The locking systems are differentiated by the locking type and housing design.



Series 100

The lock series 100 is made of synthetic material, which makes it lightweight and very small. It is suitable for users of any weight category. In connection with a socket attachment block NMA12A7(see page 252) the deviation of the socket gradient and the plumb line can easily be corrected.

Features and Benefits

- no body weight restriction because the lock is not a weight bearing component
- Activity level: 1 to 4 for NMA10S1 and NMA10S2
- Can be used for laminated sockets
- Plastic housing is temperature resistant up to 200 °C
- Locking unit is exchangeable
- Replacement button extension available on page 280

Ordering Information

Lock Series 100			
Part Number		Pin	Weight
1	NMA10S1	Clutch	95g
2	NMA10S2	Ratchet	90g

Additional Parts Ordering Information

Housing Variants	Compatible with
NMA10S1/E1	NMA10S1

Spare Parts Ordering Information

See page 280 for a full list of Series 100 spare parts

1



2



Series 150

The lock series 150 is characterised by its very small design and a high-strength aluminium housing. The aluminium housing can be removed from the deep-drawing socket and used for the laminating socket. Processing is carried out using common deep-drawing or laminating methods. In conjunction with a NMA12A3, NMA12A5 or NMA12A7 Socket Attachment Block, the deviation of the socket gradient and plumb line can be easily corrected.

Features and Benefits

- No body weight restriction because the lock is not a weight bearing component
- Includes 1 pin
- Activity level: 1 to 4 for NMA15S1 and NMA15S2
- Activity level: 1 to 3 for NMA15S3
- Can be used for thermoplastic and laminated sockets
- Aluminium housing
- Mounting height: approx 23 mm
- Clutch-Lock with "EasyClick" system: optimised pull-in and release mechanism
- Twist-proof pin guide made of stainless steel
- Locking unit completely exchangeable

Ordering Information

Lock Series 150			
Part Number		Pin	Weight
1	NMA15S1	Clutch	95g
2	NMA15S2	Ratchet	90g
3	NMA15S3	Smooth	85g

Additional Parts Ordering Information

Housing Variants	Compatible with
NMA15S1/E1	NMA15S1
NMA15S2/E1	NMA15S2
NMA15S3/E1	NMA15S3

Spare Parts Ordering Information

See page 280 for a full list of Series 150 spare parts

1



2



3



Series 200

The lock series 200 by Streifeneder is made of aluminium and is distinctive due to its light and flat design. Distally, various socket adapters can be used.

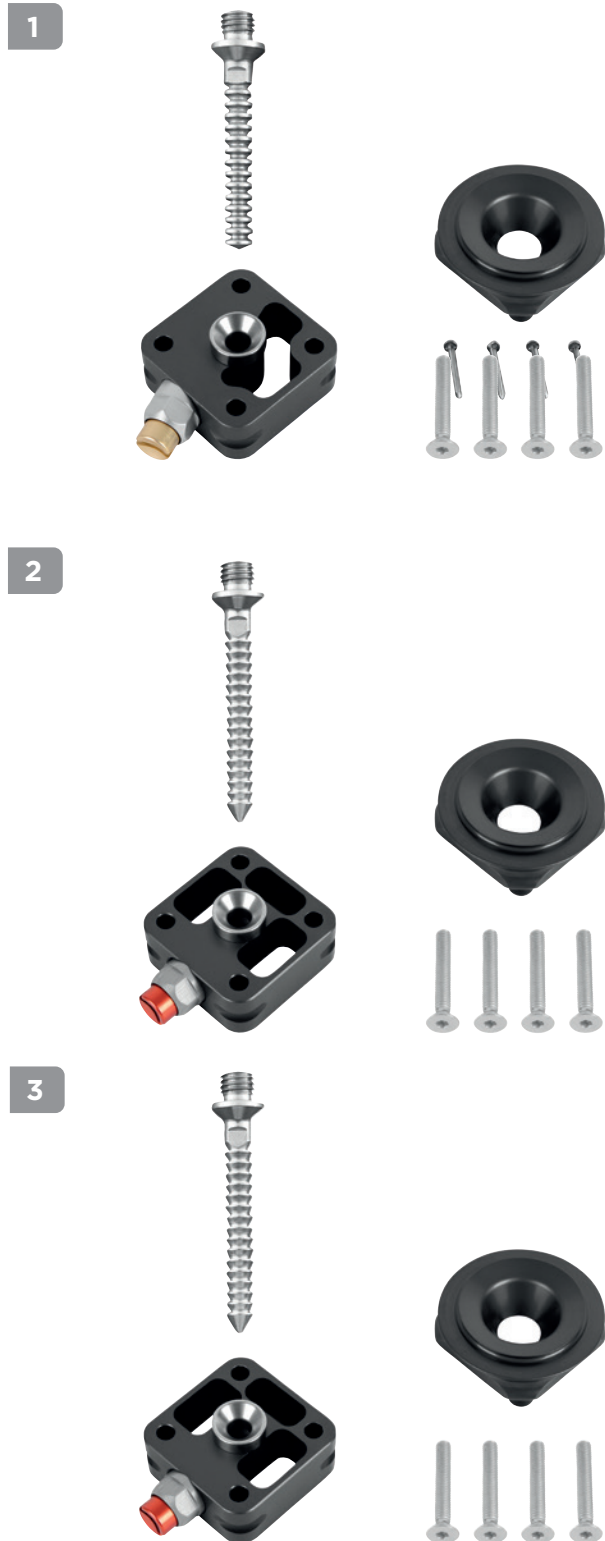

Features and Benefits

- Max. patient weight: 125kg
- Includes 1 pin & lamination disc
- Activity level: 1 to 4 for NMA20S1 and NMA20S2
- Activity level: 1 to 3 for NMA20S3
- Can be used for thermoplastic and laminated sockets
- Aluminium housing

Please note: For direct load transmission from lamination disc to different adapters use the countersunk screw NMA22A5/M6x40

- Clutch-Lock with "EasyClick" system: optimised pull-in and release mechanism light, flat construction
- Non-rotating lamination disc with multiform ring
- Continuous guide bushing made of stainless steel
- Distally with channel for planar connection of all socket adapters with 4-hole connection
- Easy cleaning and replacing of complete locking unit is possible without dismantling the prostheses
- With Lamination Disc NMA20S1/E5

Ordering Information

Lock Series 200				
Part Number	Lock Type	Pin	Weight	
1	NMA20S1	Clutch-Lock	Clutch	198 g
2	NMA20S2	Shuttle-Lock	Ratchet	172 g
3	NMA20S3	Shuttle-Lock	Smooth	178 g

Spare Parts Ordering Information

See page 280 for a full list of Series 200 spare parts

Series 300

The latest weight-optimised lock series 300 from Streifeneder is made of wear-resistant plastic is very suitable for direct lamination or for complete exchange, if you utilise a lamination dummy NMA30S1/D56 - NMA30S1/D76.

Different lamination discs and socket adapters can be attached with 6 screws in the distal end of the socket.



Features and Benefits

- Max. body weight: 100 kg
- Activity level: 1 to 4 for NMA30S1 and NMA30S2
- Activity level: 1 to 3 for NMA30S3
- Build Height: 33mm
- Can be used for thermoplastic and laminated sockets
- Plastic housing is temperature resistant up to 200 °C
- Clutch-Lock with "EasyClick" system: optimised pull-in and release mechanism
- Lightweight, weight-optimised construction made of plastic
- Multifunctionally applicable
- Continuous guide bushing, rotation secured, made of stainless steel
- Locking unit completely exchangeable
- Easy cleaning and replacing of complete locking unit is possible without dismantling the prostheses
- Incl. special sealing grease NMA22A100

Ordering Information

Lock Series 300			
Part Number	Lock Type	Pin	Weight
1	NMA30S1	Clutch-Lock	Clutch 77g
2	NMA30S2	Shuttle-Lock	Ratchet 82g
3	NMA30S3	Shuttle-Lock	Smooth 80g

Additional Parts Ordering Information

Housing Variants	Compatible with
NMA30S1/E1	N30S1
NMA30S2/E1	N30S2
NMA30S3/E1	N30S3

Mini Lamination Disc	Material	Eff. Height	Max Weight
NMA16A10	Titanium	6mm	100kg

Lamination Anchor	Material	Eff. Height	Max Weight
NMA16A30	Titanium	6mm	75kg

Lam. Disc	Form / Weight	Material	Mount. Height	Max Weight
NMA16A3	Ø 64 mm/45 g	Aluminium	9mm	150kg
NMA16A5	[] 52 mm/32 g	Aluminium	9mm	150kg

Spare Parts Ordering Information

See page 281 for a full list of Series 300 spare parts

Series 400

The series 400 from Streifeneder is especially suitable for AK and BK-residual limbs with very large distal circumference. The housing, made of a high quality aluminium alloy, is distally fitted with an adjustment core for a compact construction.



Features and Benefits

- Max. patient weight: 125kg
- Activity level: 1 to 4 for NMA40S1 and NMA40S2
- Activity level: 1 to 3 for NMA40S3
- Mounting height: approx. 33 mm
- Can be used for thermoplastic and laminated sockets
- Aluminium housing

Please note: order press button extensions for geriatric patients or big sockets separately

- Clutch-Lock with "EasyClick" system: optimised pull-in and release mechanism
- With socket adapter NMA10A21/S for laminating into the socket
- With lamination dummy NMA22A9
- With distal adjustment core
- Easy cleaning and replacing of complete locking unit
- Incl. special sealing grease NMA22A100

Ordering Information

Lock Series 400				
Part Number	Lock Type	Pin	Weight	
1	NMA40S1	Clutch-Lock	Clutch	158g
2	NMA40S2	Shuttle-Lock	Ratchet	147g
3	NMA40S3	Shuttle-Lock	Smooth	136g

Additional Parts Ordering Information

Lamination Anchor for Series 400
NMA10A21/S

Spare Parts Ordering Information

See page 281 for a full list of Series 400 spare parts

Series 500

The lock series 500 from Streifeneder offers a time-saving advantage when manufacturing thermoplastic sockets. Through the simple construction the housing will be completely enclosed by the socket material. The integrated cutting protection allows a fast and safe uncovering of the adjustment core.



Features and Benefits

- Max. patient weight: 125kg
- Clutch-Lock with "EasyClick" system: optimised pull-in and release mechanism
- Housing with pull-in channel
- Mounting height: approx 37mm
- Activity level: 1 to 4
- Can be used for thermoplastic and laminated sockets
- Easy cleaning and replacing of complete locking unit is possible without dismantling the prostheses

Ordering Information

Lock Series 500				
Part Number	Lock Type	Pin	Weight	
1	NMA50S1	Clutch-Lock	Clutch	170g
2	NMA50S2	Shuttle-Lock	Ratchet	162g

Spare Parts Ordering Information

See page 281 for a full list of Series 500 spare parts

System Replacement Parts

Replacement Pins			
Part Number	Length	Pin Type	Application
NMA10S1/E335	35mm	Geared	Clutch-Lock
NMA10S1/E350	50mm	Geared	Clutch-Lock
NMA10S1/E365	65mm	Geared	Clutch-Lock
NMA10S1/E385	85mm	Geared (L)	Clutch-Lock
NMA10S2/E335	35mm	Rastered	Shuttle-Lock
NMA10S2/E350	35mm	Rastered	Shuttle-Lock
NMA10S2/E365	35mm	Rastered	Shuttle-Lock
NMA10S3/E335	35mm	Plain	Easy-Lock
NMA10S3/E350	50mm	Plain	Easy-Lock
NMA10S3/E365	65mm	Plain	Easy-Lock

Replacement Lock Units		
Part Number	For Pin Type	Application
NMA10S1/E2	Geared	Clutch-Lock
NMA10S2/E2	Rastered	Shuttle-Lock
NMA10S3/E2	Plain	Easy-Lock
NMA10S2/WE2	Rastered	Shuttle-Lock

L = Long ■ = Waterproof

Vacuum-Valve	Description
NMA10S4/L	Left Thread
NMA10S4/R	Right Thread

Replacement Push Button Extension		
Part Number	Material	Length
1 NMA10S1/45	Plastic	45mm
2 NMA10S1/70	Aluminium	70mm
3 NMA10S1/85	Aluminium	85mm



Sealing Grease (Stick Wax)	
Part Number	Description
NMA22A100	5ml



Series 100/150

Lamination Dummy for Series 100/150	
Part Number	Description
NMA10S1/E6	Shuttle and Easy Lock
NMA10S1/E6L	Clutch-Lock (left-hand thread)

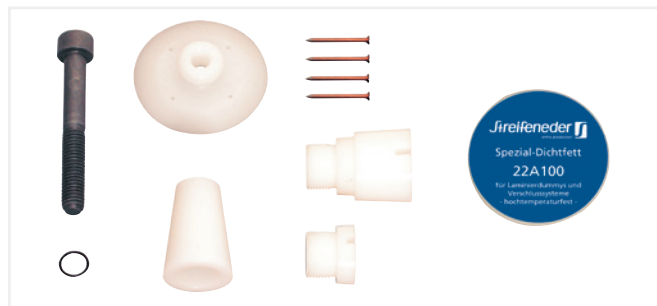

Series 200

1. Lamination Disc for Series 200 (64mm)
NMA20S1/E5
2. Lamination Dummy for Series 200
NMA20S1/E51
3. Deep-Drawing Adapter Ring
NMA20S1/E53



Series 300

1. Lamination Dummy for Series 300	
Part Number	Description
NMA30S1/E6	Shuttle and Easy Lock
NMA30S1/E6L	Clutch-Lock(left-hand thread)

2. Lamination Dummy	
Part Number	Description
NMA22A13	Replacement part for Lam. disc NMA16A3 & NMA16A5

3. Lamination Dummy		
Part Number	For Lock	Diameter (Ø) / Mat.
30S1/D56	30S2, 30S3	56 mm / POM
30S1/AD56	30S2, 30S3	56 mm / Aluminium
30S1/AD66	30S1, 30S2, 30S3	66 mm / Aluminium
30S1/AD76	30S1, 30S2, 30S3	76 mm / Aluminium

4. Hopper		
Part Number	For Lock	Diameter (Ø)
30S1/E56	30S2, 30S3	56 mm
30S1/E66	30S1, 30S2, 30S3	66 mm
30S1/E76	30S1, 30S2, 30S3	76 mm

Sealing Disc		
Part Number	Weight	Material
NMA30S4/D	10 g	Silicone

Sealing Plunger for Series 300	
Part Number	Description
NMA30S4/P	



Series 400

Lamination Dummy for Series 400	
Part Number	Description
NMA22A9	

Series 500

Lamination Dummy for Series 500	
Part Number	Description
NMA50S1/E5	Shuttle and Easy Lock
NMA50S1/E5L	Clutch-Lock (left-hand thread)

Sealing Plunger		
Part Number	Weight	Material
NMA50S4/P	30 g	POM black



Waterproof Shuttle-Lock

Lamination Dummy	
Part Number	Description
NMA10S1/E6	Shuttle and Easy Lock
Replacement Lock Unit for Waterproof Shuttle-Lock	
NMA10S2/WE2	